

DATA SHEET

3942

Service Delivery Switch



Ciena's 3942 Service Delivery Switch is a compact, high-density packet switch that delivers low TCO in metro networks that require cost-effective copper interfaces for MDU/MTU deployments.

The 3942 is optimized for compact, dense metro access and delivery of Ethernet services in MDU/MTU environments, including a growing number of MEF-defined Ethernet business services (E-Line, E-LAN, E-Tree, E-Access).

It supports 4 10GE/1GE multi-rate SFP/SFP+ ports and 20 10/100/1000 Base-TX copper ports. Its form factor complements Ciena's 5142 and 5160 Service Aggregation Switches, enabling optimization of gigabit aggregation costs and density to suit the needs of primarily copper environments.

The 3942 is based on the Service-Aware Operating System (SAOS) used in all Ciena packet switches, providing operational efficiency and consistent system attributes. SAOS delivers benefits across all Ethernet access and aggregation applications, including:

- Rapid implementation of the latest advances in Ethernet technologies, as well as new services and standards proposed by the IEEE, IETF, MEF, and ITU
- Improved efficiency and cost savings resulting from a common deployment and service provisioning model
- Service-offering ubiquity, permitting rapid rollout of new services across the entire network
- MEF CE 2.0-compliant Ethernet service offerings for E-Line, E-LAN, E-Tree, and E-Access port-based and VLAN based variants

Features and Benefits

- Is a cost-effective solution for MDU/MTU deployments where copper infrastructure is deployed in building risers and distribution closets
- Features dense, low-footprint GE aggregation in a non-blocking, wire-speed architecture with 20 10/100/1000Base-TX ports and 4 1GbE/10GbE multi-rate SFP+ ports
- Offers dual AC or DC power in a high-availability, 1RU package
- Supports zero-touch provisioning to minimize OPEX and accelerate service turn-up while providing a service 'birth certificate' with built-in service activation testing
- Complies with MEF CE2.0 specifications for E-Line, E-LAN, E-Tree, and E-Access services
- Incorporates flexible transport options, including G.8032 rings, 802.1q VLANs, 802.1ad Provider VLANs (Q-in-Q), IP/MPLS, and MPLS-TP
- Includes on-board performance benchmark testing capabilities for end-to-end SLA verification
- Employs hardware-assisted OAM capabilities for performance and fault management
- Works in concert with Ciena's OneControl Unified Management System

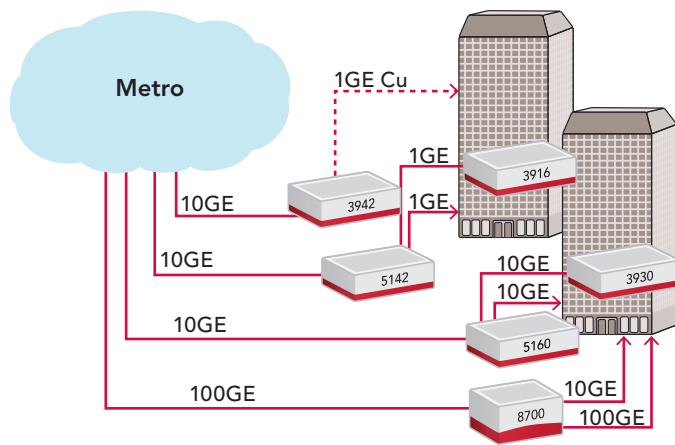

Figure 1. Metro Ethernet Business Services

Extensive Carrier Ethernet Transport Options

The 3942 provides unmatched flexibility to address multiple applications, networking models, and deployment environments without sacrificing service capabilities.

The 3942 provides a variety of packet transport options for CE 2.0-compliant MEF Ethernet services, including G.8032 rings, 802.1q VLANs, 802.1ad Provider VLANs (Q-in-Q), IP/MPLS, and MPLS-TP.

Operators can use combinations of these capabilities to accommodate the specific needs of their packet network deployment. The 3942 supports interworking between these transport options via a sophisticated and scalable virtual switching architecture, leading to complete service flexibility and optimal utilization of network resources. With an extensive set of MPLS features, the solution also supports resilient Layer 2 VPNs and enables service providers to offer connection-oriented MPLS-TP-based services on metro networks, extending the functionality and scalability of existing MPLS networks to accommodate the behavior and operational practices of traditional transport networks.

Key protocol capabilities include:

- MPLS Pseudowire Emulation Edge-to-Edge (PWE3), which supports MPLS Virtual Private Wire Services (VPWS)
- Virtual Private LAN Services (VPLS) and Hierarchical-VPLS (H-VPLS) supporting L2 VPNs
- MPLS label edge router functionality, enabling application as a VPLS/H-VPLS Provider Edge switch and an H-VPLS MTU-s customer edge switch

- Dynamic MPLS control plane, including Label Distribution Protocol (LDP) for VC signaling; OSPF-TE and IS-IS-TE for MPLS Tunnel Routes; and RSVP-TE for Label Switched Path (LSP) establishment
- MPLS-TP static bidirectional co-routed LSPs for deterministic traffic paths, with centralized service provisioning via Ciena's OneControl Unified Management System
- MPLS OAM capabilities, including LSP Ping and LSP traceroute, with support for MPLS-TP in-band GAL/GACH, and AIS/LDI enhanced fault detection

The design of the 3942 also provides flexibility to enable deployment in a wide range of physical operating environments, supporting:

- Extended temperature range (-5°C to +65°C), enabling deployment in a wide variety of locations
- Fixed power options for wide-range DC (-36V DC, -48V DC), AC (100-240V), and simplex or duplex powering applications

Zero-Touch Provisioning

Ciena's zero-touch provisioning simplifies system turn-up and enables device deployment, service turn-up, and Service Level Agreement (SLA) performance testing to be run from the Network Operations Center (NOC). This efficiency dramatically lowers OPEX, eliminating the need for on-site personnel or adjunct test equipment and ensuring consistent, reproducible test reports ready for immediate transmission to the customer for service acceptance. Operators can ramp service roll-outs faster, and at lower cost, because the minimized training requirement permits use of a wider pool of technicians.

The 3942 includes a hardware engine to provide RFC2544 and Y.1564 performance benchmark testing, enabling full line-rate traffic measurements end-to-end across the Ethernet virtual circuit. This ability dramatically lowers OPEX by eliminating the need for on-site personnel or expensive test gear. This approach also improves end-customer satisfaction by enabling NOC personnel to proactively respond to network events and increasing performance visibility for end-customer SLA reporting.

Fine-Grained SLA Monitoring and Enforcement

As end-customer applications become increasingly dependent on tight SLA guarantees, successful operators need to deliver advanced Quality of Service (QoS) offerings and accurately and efficiently monitor the health and performance of those services.

The 3942 implements carrier-class hierarchical QoS that permits delivery of a wide range of traffic types and rates over a single access infrastructure without interference or degradation. These capabilities enable greater revenue generation by utilizing available network resources efficiently, while improving customer relations with enforceable and reliable SLAs.

Ciena's portfolio incorporates an extensive Operations, Administration, and Maintenance (OAM) feature suite providing comprehensive link, service, and network monitoring and performance metrics.

The 3942's OAM features include:

- ITU-T Y.1731 performance monitoring for delay, jitter, and loss with hardware-assisted performance
- IEEE 802.1ag Connectivity Fault Management (CFM) with hardware-assisted performance
- IEEE 802.3ah Ethernet in the First Mile (EFM)
- IEEE 802.1AB Link Layer Discovery Protocol (LLDP)
- IETF RFC 5618 TWAMP sender and responder for L3 SLA Monitoring
- MPLS/MPLS-TP OAM suite (LSP ping, traceroute, etc.)
- Full line-rate, built-in RFC 2544/ITU-T Y.1564 performance benchmark test generation and reflection

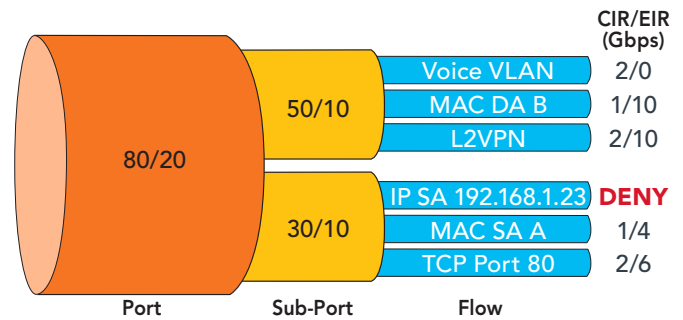

Figure 2. Granular classification and SLA enforcement

OneControl Unified Management System

Ciena's OneControl offers a unique and comprehensive solution to manage mission-critical networks that span across domains (access, metro, and core), with unprecedented visibility through protocol layers (packet as well as photonic and transport). With this innovative approach, OneControl returns network and services control to the operator.

OneControl unites the management of Ciena's Packet Networking, Converged Packet Optical, and Optical Transport portfolios under a single solution. With its unique toolset of comprehensive management features, OneControl puts the control of critical networks at the operator's fingertips. Through a unified GUI and common management model, NOC operators can rapidly deploy new service offerings that cut across domains (access, metro, and core) and coordinate across network protocol layers to ensure efficient use of critical network assets and bandwidth optimization.

This efficiency provides comprehensive management and control from the access customer hand-off points, through the metro, and into the network core. The OneControl GUI allows NOC personnel to create and activate end-to-end packet services. OneControl provides complete visualization of the entire end-to-end service multi-layer correlation, facilitating proactive root cause analysis and troubleshooting.

Technical Information

Interfaces

4 x 1/10G SFP+ ports
20 x 10/100/1000Base-TX RJ-45 ports
1 x 10/100/1000M RJ-45 Management Port
1 x Console Port (RJ-45, EIA-561)

Ethernet

IEEE 802.3 Ethernet
IEEE 802.3-2008 10-Gigabit Ethernet
IEEE 802.3z Gigabit Ethernet
IEEE 802.3ab 1000Base-T
IEEE 802.3u 100Base-TX
IEEE 802.1D MAC Bridges
IEEE 802.1Q VLANs - Including .1p Priority
IEEE 802.1ad Provider Bridging (Q-in-Q) VLAN full S-VLAN range
VLAN tunneling (Q-in-Q) for Transparent LAN Services (TLS)
Per-Port MAC Learning Control
Rapid / Multiple Spanning Tree (RSTP/MSTP)
IEEE 802.3ad Link Aggregation Control Protocol (LACP)
Multi-Chassis LAG Active/Standby Protection
ITU-T G.8032 Ethernet Rings Protection Switching
Jumbo Frames to 9216 bytes
Layer 2 Control Frame Tunneling
Private Forwarding Groups
MEF CE 2.0 Compliant
E-LINE: EPL, EVPL
E-LAN: EP-LAN, EVP-LAN
E-Access: Access EPL, Access EVPL
E-Tree: EP-Tree, EVP-Tree

Carrier Ethernet OAM

IEEE 802.1ag Connectivity Fault Management (CFM)
IEEE 802.3ah Ethernet in the First Mile (EFM)
IEEE 802.1AB Link Layer Discovery Protocol (LLDP)
ITU-T Y.1731 Performance Monitoring
RFC 2544 Performance Benchmarking Test Generation and Reflection up to 1GE
ITU-T Y.1564 Ethernet Service Activation Test Methodology
RFC 5618 TWAMP Responder and Receiver TWAMP Sender
TWAMP +/- 1ms timestamp accuracy
Dying Gasp with Syslog and SNMP Traps

Quality of Service

8 Hardware Queues per Port
Committed, Excess Information Rate (CIR, EIR)
Classification based on
IEEE 802.1D priority
VLAN, source port, destination port
IP Precedence and IPDSCP
Layer 2, 3, 4 Quality of Service
Ingress metering per-port
Ingress metering per-port per-CoS
Ingress metering per-port per-VLAN
Up to 4,000 Ingress Meters per-port
Up to 4,000 Ingress Meters per-system
C-VLAN Priority to S-VLAN Priority Mapping
S-VLAN Priority based on C-VLAN ID
Per-VLAN Classification, Metering, and Statistics
Per-port, per-VLAN QoS with CIR and EIR traffic on Egress Queues

MPLS/VPLS/MPLS-TP

RFC 2205, 3031, 3036, 3985 MPLS Pseudowire Emulation Edge-to-Edge (PWE3)
RFC 5654 MPLS-Transport Profile (TP)
LSP Static provisioning
1:1 Tunnel protection
LSP BFD via Gal/Gach
MPLS Virtual Private Wire Service (VPWS)
RFC 4762 VPLS (Virtual Private LAN Service) and Hierarchical VPLS (H-VPLS)
Provider Edge (PE-s) Functionality for VPLS and H-VPLS
VPLS with multiple VPLS Mesh Virtual Circuits
H-VPLS with Hub and Spoke Virtual Circuits
MTU-s Functionality for H-VPLS deployment
MTU-s Multihoming (redundant VCs to different PE-s switches)
MPLS Virtual Circuit as H-VPLS spoke Virtual Circuit
Q-in-Q Ethernet Virtual Circuit as H-VPLS spoke Virtual Circuit
MPLS Label Switch Path (LSP) Tunnel Groups
MPLS Label Switch Path (LSP) Tunnel Redundancy
Layer 2 Control Frame Tunneling over MPLS Virtual Circuits
RFC 3209 RSVP-TE (for MPLS Tunnel Signaling)
RFC 3630 OSPF-TE (for MPLS Tunnel Routes)
RFC 3784 IS-IS-TE (for MPLS Tunnel Routes)
RFC 3036 LDP & Targeted LDP (for VPLS VC signaling)
RFC 4090 MPLS Fast ReRoute signaling
LSP Ping & Traceroute

Multicast Management

RFC 2236 IGMPv2 Snooping
IGMPv3 PDU support
IGMP Domains
IGMP Message Filtering
IGMP Inquisitive Leave
Broadcast/Multicast Storm Control
Unknown Multicast Filtering
Well-known Protocol Forwarding

Network Management

Enhanced CLI
CLI-based configuration files
SNMP v1/v2c/v3
SNMPv3 Authentication and Message Encryption
RFC 1213 SNMP MIB II
RFC 1493 Bridge MIB
RFC 1643 Ethernet-like Interface MIB
RFC 1573 MIB II interfaces
RFC 1757 RMON MIB - including persistent configuration
RFC 2021 RMON II and RMON Statistics
Per-VLAN Statistics
RADIUS Client and RADIUS Authentication
RFC 2866 RADIUS Accounting
TACACS + AAA
RFC 2131 DHCP Client
RFC 3315 DHCP for IPv6 (DHCPv6)
RFC 6221 Lightweight DHCPv6 Relay Agent (LDRA)
RFC 1305 NTP Client
RFC 1035 DNS Client
Telnet Server
RFC 1350 Trivial File Transfer Protocol (TFTP)
RFC 959 File Transfer Protocol (FTP)
Secure File Transfer Protocol (SFTP)
Secure Shell (SSHv2)
Syslog with Syslog Accounting
Port State Mirroring
Virtual Link Loss Indication/Remote Link Loss Forwarding (VLLI/RLLF)
Dual-Stack IPv4/IPv6 management plane
Local Console Port
Comprehensive Management via Ethernet Services Manager
Remote Autoconfiguration via TFTP, SFTP
Software download/upgrade via TFTP, SFTP

Technical Information continued

Service Security

Common Criteria EAL2 compliant and certified
Egress Port Restriction
IEEE 802.1X Port-Based Network Access Control (RADIUS/MD5)
Layer 2, 3, 4 Protocol Filtering
Broadcast Containment
User Access Rights
Per-port or per-VLAN Service Access Control
Hardware-based DOS Attack Prevention
MAC Address Table Capacity
32,000 MAC addresses
Power Requirements
Two built-in redundant power supplies
DC Input: -48,-/+36 VDC (nominal)*
AC Input: 100V, 240V AC (nominal)
AC Frequency: 50/60 Hz
Maximum Power Input: 86W

Agency Approvals

Agency Marks:

NRTL (Canadian Standards Association)
CE mark (European Union)
EMC Directive (2014/30/EU)
LVD Directive (2006/95/EC)
RoHS2 Directive (2011/65/EU)
Australia C-Tick (Australia/New Zealand)
VCCI (Japan)

Emissions:

FCC Part 15 Class B
Industry Canada ICES-003 Class B
VCCI Class B
CISPR 22 Class B
GR-1089 Issue 6
EN 55022

Immunity (EMC):

CISPR 24
EN 55024
GR-1089 Issue 6
EN 300 386

Power:

ETSI EN 300 132

Safety:

EN 60950-1
CAN/CSA C22.2 No. 60950-1-07
UL 60950-1 2nd Ed
IEC 60950-1

Environmental:

RoHS2 Directive (2011/65/EU)
WEEE 2002/96/EC

Environmental Characteristics

GR-63-CORE, Issue 4 – NEBS Level 3
GR-1089 Issue 6 – NEBS Level 3
GR-3108 Issue 2 Network Equipment in the
Outside Plant (OSP) Class 2
ETSI 300 019 Class 1.2, 2.2, 3.1E
Operating Temperature:
23°F to +149°F (-5°C to +65°C)
Storage Temperature:
-40°F to +158°F (-40°C to +70°C)
Relative Humidity:
5% to 90% (non-condensing)

Physical Characteristics

Dimensions: 17.5" (W) x 9.9" (D) x 1.75"(H);
444mm (W) x 252mm (D) x 44mm (H)
Weight: 9.9 lbs; 4.5kg

* Denotes features available in a future release

Ordering Information	
Part Number	Product Description
170-3942-900	3942, (4)1G/10G SFP+, (20)10/100/1000M RJ 45, Dual AC Power, Req. Power Cable
170-3942-901*	3942, (4)1G/10G SFP+, (20)10/100/1000M RJ 45, Dual DC Power
Software	
Required OS Base System Perpetual Software Licenses	
S70-0025-900	SAOS Advanced Ethernet Perpetual Software License for 3942
Optional OS Applications	
S70-0025-901	SAOS Advanced OAM Perpetual Software License for 3942
S70-0025-902	SAOS Advanced MPLS Application Perpetual Software License for 3942
S70-0025-903	SAOS Advanced 10G Perpetual Software License for 3942
170-0204-900	SAOS Advanced Security Perpetual Software License for 3942
ESM Related	
S70-0026-900	ESM Carrier ED Right to Manage Perpetual Software License for 3942

Connect with Ciena now

